



JA Solar PV Bifacial Double-glass Modules Installation Manual

JA Solar Technology Co., Ltd.

CONTENTS

.....	1
1 Introduction	1
2 Codes and Regulations.....	1
3 General.....	1
3.1 Product Identification.....	1
3.2 Conventional Safety.....	2
3.3 Electrical Performance Safety.....	2
3.4 Operating Safety	3
3.5 Fire Safety.....	4
4 Installation Condition.....	4
4.1 Installation Position and Working Environment.....	4
4.2 Tilt Angle Selection	6
5 Mechanical Installation.....	6
5.1 Conventional Requirements.....	6
5.2 Installation methods.....	7
6 Electrical Installation.....	14
6.1 Electrical Property	14
6.2 Cables and Wiring	15
6.3 Connectors	16
6.4 Bypass Diodes.....	17
7 Grounding	17
7.1 Grounding by Using Grounding Bolt	18
7.2 Grounding by using unused mounting hole	18
8 Operation and Maintenance.....	19
8.1 Cleaning.....	19
8.2 The visual inspection of the modules.....	20
8.3 Inspection of the connector and the cable.....	20
Product Supplement	20

1 Introduction

Thank you for choosing JA SOLAR modules!

This Installation Manual contains essential information for electrical and mechanical installation that you must know before handling and installing JA Solar modules. This Manual also contains safety information you need to be familiar with. All the information described in this Manual is the intellectual property of JA Solar and is based on the technologies and experience that have been acquired and accumulated by JA Solar.

This Manual does not constitute a warranty, expressed or implied. JA Solar does not assume responsibility and expressly disclaims liability for loss, damage, or expense arising out of or in any way connected with installation, operation, use or maintenance of modules. No responsibility is assumed by JA Solar for any infringement of patents or other rights of third parties that may result from use of modules. JA Solar reserves the right to make changes to the product, specifications or installation manual without prior notice.

Failure to comply with the requirements listed in this manual will invalidate the Limited Warranty for modules as provided by JA Solar at the same time of sale to the direct customer. Additional recommendations are provided to enhance safety practices and performance results. Please provide a copy of this manual to the PV system owner for their reference, and inform them of all relevant aspects of safety, operation, and maintenance.

2 Codes and Regulations

The mechanical and electrical installation of PV systems should be performed in accordance with all applicable codes, including electrical codes, building codes and electric utility interconnection requirements. Such requirements may vary for mounting location. Requirements may also vary with system voltage, and for DC or AC application. Contact local authorities for governing regulations.

3 General

3.1 Product Identification

Each module has three labels providing the following information:

1. Nameplate: describes the product type; Peak power, Max power current, Max power voltage, Open circuit voltage, Short circuit current, all as measured under standard test conditions; Certifications mark, the maximum system voltage etc.
2. Current sorting: modules are sorted out according to their Max power current, referred as a corresponding symbol "Current class X" attached, in which "X" takes the value H, M or L(H marks physically the highest current). To get optimal performance out of a string of modules it is recommended to connect only modules of the same "Current class X" class (for example only H modules) in one given string. For the rest of modules with different current classes, the modules with adjacent current class can be installed in one given string.
3. Serial number: each individual module has a unique serial number. The serial number has 16 digits. The

1st and the 2nd digits are the year code, and the 3rd is the month code (A, B, C stands for October, November and December respectively). For example, 121XXXXXXXXXXXXXXXX means the module was assembled and tested in the January of 2012. Each module has only one bar code. It is permanently attached to the interior of the module and is visible from the top front of the module. This bar code is inserted prior to laminating. In addition, you can find the same barcode on the frame.

3.2 Conventional Safety

JA Solar modules are designed to meet the requirements of IEC 61215 and IEC 61730, application class A. Modules rated for use in this application class may be used in system operating at greater than 50V DC or 240W, where general contact access is anticipated. Modules qualified for safety through IEC 61730-1 and IEC 61730-2 and within this application class are considered to meet the requirements for safety class II equipment.

When modules are mounted on rooftops, the roof must have a fire resistant covering suitable for this application. Rooftop PV systems should only be installed on rooftops capable of handling the additional weighted load of PV system components, including modules, and have a complete analysis of the structure performed by a certified building specialist or engineer.

For your safety, do not attempt to work on a rooftop until safety precautions have been identified and taken, including without limitation fall protection measures, ladders or stairways, and personal protective equipment.

For your safety, do not install or handle modules under adverse conditions, including without limitation strong or gusty winds, and wet or frosted roof surfaces.

3.3 Electrical Performance Safety

Photovoltaic modules can produce DC electricity when exposed to light and therefore can produce an electrical shock or burn. DC voltage of 30 Volts or higher is potentially lethal.

Modules produce voltage even when are not connected to an electrical circuit or load. Please use insulated tools and electrically insulated gloves when working with modules in sunlight.

Modules have no on/off switch. Modules can be rendered inoperative only by removing them from sunlight, or by fully covering their front surface with cloth, cardboard, or other completely opaque material, or by working with modules face down on a smooth, flat surface.

In order to avoid arcs and electrical shock, please do not disconnect electrical connections under load. Faulty connections can also result in arcs and electrical shock. So please keep connectors dry and clean, and ensure that they are in proper working condition. Never insert metal objects into the connector, or modify them in any way in order to secure an electrical connection.

In order to avoid external matter such as sand or water vapour from entering and causing connection safety problems, once the modules are taken out of the packing box and installed, the connectors between the modules need to be connected in time, and the connectors need to be kept dry and clean during the installation process. Before connecting the modules at both ends of the string to the combiner box or inverter, plug the connectors with dust plugs to avoid contamination of the connectors.

Please note that contamination from sand, dust and water can cause arcing, electric shock or difficulty in plugging the connectors, etc. We recommend adding connector dust plugs as a temporary protective measure

in dusty, saline and polluted areas, and do not recommend long-term use (within 1 month).

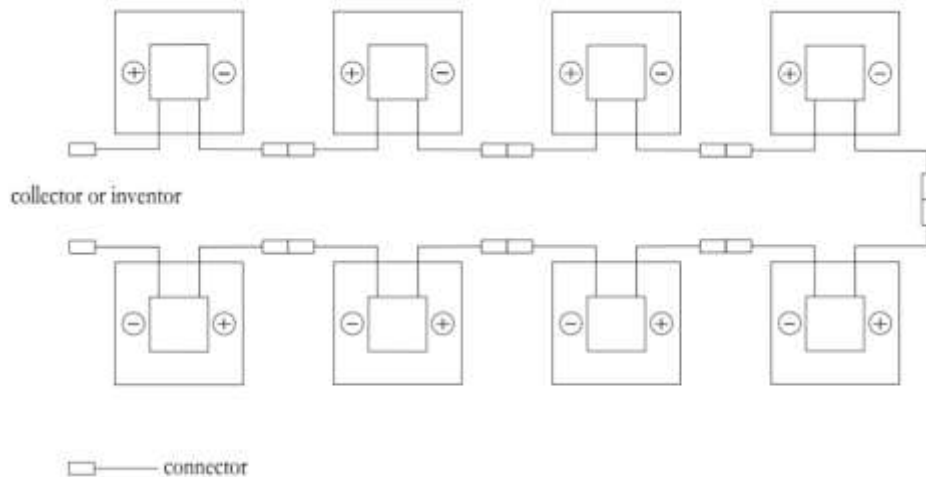

Reflection from snow or water can increase sunlight and therefore boost current and power. In addition, colder temperatures can substantially increase voltage and power.

If the glass or other material is damaged, please wear personal protection equipment and separate the module from the circuit.

Work only under dry conditions, and use only dry tools. Do not handle modules when they are wet unless wearing appropriate protective equipment. If you need to clean the modules, please follow the cleaning requirements mentioned in the manual.

Installation must be carried out under the guidance of a qualified electrician.

No matter the weather conditions, personnel entering the power station shall wear safety helmet, insulating gloves and insulating shoes correctly, taking self-safety protection measures.

3.4 Operating Safety

Do not open the package of JA Solar modules until they are ready to be installed during transportation and storing.

At the same time please protect the package against exposure to damage. Secure pallets from falling over.

Do not exceed the maximum height of pallets to be stacked, as indicated on the pallet packaging.

Store pallets in a ventilated, rain-proof and dry location until the modules are ready to be unpacked.

Please unpack the package of JA Solar modules according to “Standard Unpacking Instruction of JA Solar PV Modules”.

Do not lift the modules by grasping the module’s junction box or electrical leads in any condition.

Do not stand or step on the modules.

Do not drop the modules on another module.

Do not place any heavy objects on the modules to avoid glass breakage.

Be cautious when setting the modules down on to a surface, especially on the corner of the modules.

Inappropriate transport and installation may break the modules.

Do not attempt to disassemble the modules, and do not remove any attached nameplates or components from the modules.

Do not apply paint or adhesive to the modules top surface.

Do not drill holes in the frame. This may compromise the frame strength and cause corrosion of the frame.

Do not scratch the anodized coating of the frame (except for grounding connection). It may cause corrosion of the frame or compromise the frame strength.

Do not attempt to repair the modules with damaged glass.

Heavy PV modules require more than two people to carry.

The scrapped modules shall be recovered and disposed by the qualified institution.

During installation, removal, maintenance, and other related operations, it is recommended that the force applied between cables and connectors or between cables and junction boxes should be less than 60N.

In dry areas, modules are easily affected by static electricity during installation. So the installation personnel should wear anti-static assembly to ensure that the equipment and installation personnel are not affected or hurt by static electricity.

3.5 Fire Safety

Consult your local authority for guidelines and requirements for building or structural fire safety. JA solar modules have been tested in according with IEC 61730-2 standard.

For roof installations, modules should be mounted over a fire resistant covering suitable for this application, with adequate ventilation between the module backsheet and the mounting surface.

Roof constructions and installations may affect the fire safety of the building. Improper installation may create hazards in the event of a fire.

Use appropriate components such as fuses, circuit breaker and grounding connector as requires by local authority.

Do not use modules where flammable gasses may be generated.

JA modules have not been tested for explosion protection. Please consult local regulations whether the modules can be used or not.

4 Installation Condition

4.1 Installation Position and Working Environment

JA Solar modules are intended for use in terrestrial applications, no outer space use.

Do not use mirrors or other magnifiers to concentrate sunlight onto the modules.

Modules must be mounted on appropriate mounting structures positioned on suitable buildings, the ground,

or other structures suitable for modules (e.g. carports, building facades or PV trackers).

Modules must not be installed in locations where they could be submerged in water.

The recommended ambient temperature should be within -40°C (-40°F) to 40°C (104°F). The temperature limits are defined as the monthly average high and low of the installation site. The limit operating temperature should be -40°C (-40°F) and 85°C (185°F).

Ensure modules are not subject to wind or snow loads exceeding the maximum permissible loads.

The modules should be installed in a location where there's no shading throughout the year. Ensure there's no obstacle to block light near the installation site.

Lightning protection is recommended for PV systems that are to be installed in locations with high probability of lightning strikes.

Do not use modules near equipment or in locations where flammable gasses may be generated or collected.

Modules cannot be installed or used in extreme areas or weather conditions, and highly corrosive areas should be considered carefully.

Please adopt appropriate measures to ensure the performance and safety of the modules when they are installed or operated in areas heavy snow, extremely cold, strong wind, or near an island or desert that is prone to produce salt fog, or near water.

For areas with high wind speeds and snow loads, it is recommended to use a fixed bracket installation method. A tracking bracket installation method is not recommended, to avoid damage to modules caused by the firmness of the tracking bracket.

For areas with high wind load and snow load, it is recommended to use the fixed mounting system, rather than trackers, which can facilitate the stability and protect of the solar system from high loads. If solar modules are installed with trackers, it is recommended to use 2.5mm thickness and 60mm height and above purlin installation with 790mm, 1200mm, 1400mm holes in the module frames, not 400mm installation hole to fasten the rails.

The module frame will deform to a slight extent at low temperatures, and the maximum deformation at the frame center is generally within 15mm, which does not affect the normal installation and application of the module.

The Salt Mist corrosion resistance is optional or on Request. JA Solar modules have passed the IEC 61701 salt-mist, but galvanic corrosion can occur between the aluminium frame of the modules and mounting or grounding hardware if such hardware is comprised of dissimilar metals. JA Solar modules can be installed at seaside locations 50m to 500m from the sea, but the components should be protected against corrosion.

Modules cannot be applied for some special requirements, e.g. for marine and vehicle applications. Please refer to local law and regulations for details.

If the module is installed in the dusty environment, the ash layer on the module surface shall be cleaned regularly and immediately to prevent the ash layer from accumulating and forming hot spots on the surface and causing damage to module.

4.2 Tilt Angle Selection

The tilt angle of the modules is measured between the surface of the modules and a horizontal ground surface. The modules generates maximum power output when it faces the sun directly.

In the northern hemisphere, modules should typically face south, and in the southern hemisphere, modules should typically face north.

For detailed information on the best installation angle, please refer to standard solar photovoltaic installation guides or consult a reputable solar installer or systems integrator.

Dust building up on the surface of the modules can impair module performance. JA solar recommends installing the modules with a tilt angle of at least 10 degrees, making it easier for dust to be washed off by rain.

5 Mechanical Installation

5.1 Conventional Requirements

Ensure the installation method and supporting system of modules is strong enough to withstand all the load conditions. The Installer must provide this guarantee. The installation supporting system must be tested by the third-party organization with the analysis ability of Static Mechanical, according to the local national or international standards.

The modules mounting structure must be made of durable, corrosion-resistant and UV-resistant material.

Modules must be securely attached to the mounting structure.

Photovoltaic mounting system is the important part of PV solar systems and it plays a key role in solar system safety and electricity power generation. In order to ensure the stability and safety of photovoltaic modules, and to prevent the potential risk on PV modules, Photovoltaic mounting system design must strictly follow the photovoltaic system design specifications, and ensure the quality and system strength criteria to be fully complied with. The PV mounting system includes of mounting columns, beams, purlins, supporting rails and connection nodes.

In regions with heavy snowfall in winter, select the height of the mounting system so that the lowest edge of the modules is not covered by snow for any length of time. In addition, ensure that the lowest portion of the modules is placed high enough so that it is not shaded by plants or trees or damaged by flying sand.

When the modules are supported parallel to the surface of a building wall or roof, it is recommended that the minimum clearance of 10 cm between the modules frame and the surface of the wall or the roof , to allow air to circulate behind the modules and to prevent wiring damage.

Do not attempt to drill holes in the glass surface and the frames of the modules as this will void the warranty.

Before installing modules on a roof, ensure that the roof construction is suitable. In addition, any roof penetration required to mount the modules must be properly sealed to prevent leaks.

When installed in areas with high wind pressure and high snow pressure, the supporting fixed structure design should be carried out in strict accordance with the local design specifications to ensure that the external load does not exceed the allowable load strength limit.

Observe the linear thermal expansion of the modules frames (the recommended minimum distance

between two modules is 10mm).

The module frames will warp at low temperature.

Avoid the frame receiving the lateral tension and pressure, causing the frame off or crushing the glass. Modules have been certified for a maximum static load on the back side of 2400 Pa (i.e. wind load) and a maximum static load on the front side of 2400 Pa or 5400 Pa (i.e. wind and snow load), depending on the modules type (See "Installation position and corresponding load" below).

The mounting method must not result in the direct contact of dissimilar metals with the aluminium frame of the modules as it will result in galvanic corrosion. An addendum to IEC 60950-1 standard recommends metal combinations not exceed an electrochemical potential difference of 0.6 Volts.

JA Solar modules can be mounted in landscape or portrait orientation. For the bifacial modules, in order to maintain the energy yield of module rear side, the distance between the bottom of modules and the roof or ground surface is recommended be at least 1m.

Photovoltaic modules should be installed in accordance with JA Solar's installation manuals or recommended installation methods. Tracker installation should get the compatibility approval from JA Solar modules. Other installation methods, please contact JA Solar's technical team. Please make sure the modules are properly installed and keep the warranty valid.

5.2 Installation methods

Modules can be installed to the racks by clamps or hooks. Modules must be installed according to the following examples and recommendation. If not mounting the modules according to these instructions, please in advance consult JA Solar and must be approved by JA solar, otherwise may damage modules and void the warranty.

5.2.1 Modules installed with clamp

Module should be attached on a supporting structure rail by metal clamps.

A. It is recommended to use the clamps under the following condition or approved by system installation:

Width: Clamp A no less than 50mm, Clamp B no less than 50mm;

Thickness: No less than 3mm

Material: Aluminum Alloy, 6063-T5

Bolt: M8

Nut: M8

Washer: M8

B. Recommended bolt torque range: 18-24N·m.

C. The modules clamps should not contact the front glass or deform the frame in any way. Avoid shading effects from the modules clamps. Drainage holes on the modules frame should not be closed or obscured by the clamps. Besides, two or more screws or two full threads of a single screw shall engage the metal.

D. The fixture overlaps with the module frame A surface of at least 8mm, but not over 12mm. For the installation way parallel to the module frame, ensure that the module frame and the guide completely overlap or overlap by a depth of 20mm.

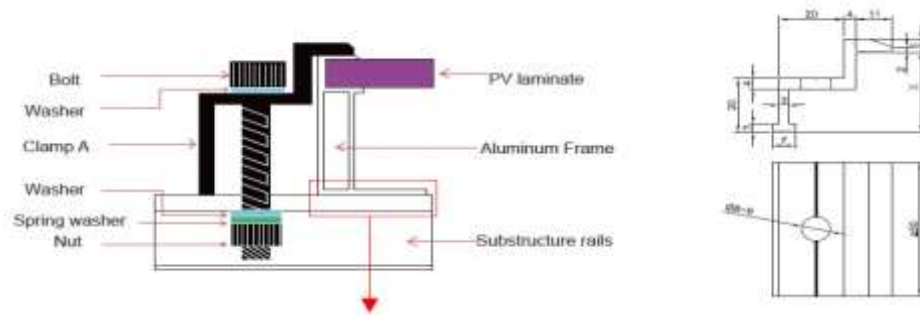

The module frame surface overlaps with the guide rail by at least 20mm

Clamp A The clamp used on the sided module (X=The height of module frame)

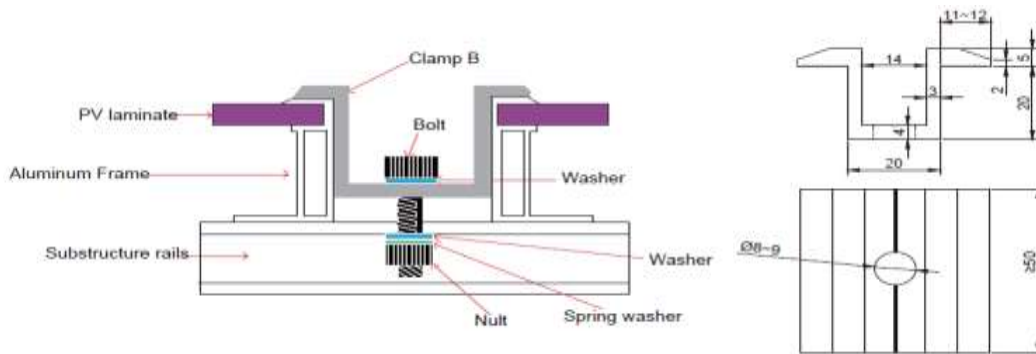

Clamp B The clamp used on the middle module

Figure 1 Mounting detail (Units: mm)

The JA limited warranty will be invalid if the substandard clamp is used (such as clamp height mismatch with module frame height) or if an incorrect installation method is used.

5.2.2 Modules installed with mounting hole

Modules should be bolted to support structures through mounting holes located in the frame's back flanges. Refer to what is shown in Figure 2 (Mounting Details).

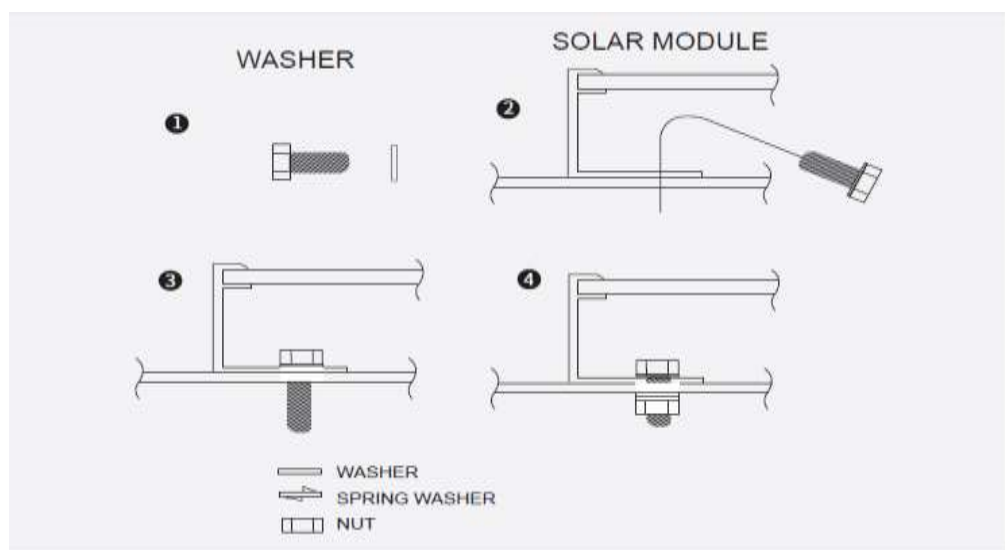

Figure 2 Mounting Details

For your reference, please use the components specified below:

- | | |
|------------------------|--|
| 1. Bolt | 2. Washer |
| Material: Q235B/SUS304 | Material: Q235B/SUS304 |
| Size: M8/M6 | Size: M8/M6, thickness $\geq 1.5\text{mm}$, outside diameter $\leq 16\text{mm}$ |
| 3. Spring Washer | 4. Nut |
| Material: Q235B/SUS304 | Material: Q235B/SUS304 |
| Size: M8/M6 | Size: M8/M6 |

Recommendations:

1. M8 screw tightening torque size range: 15-20N·m; M6 screw tightening torque size range: 8-12N·m.
2. For 30mm frame, it is recommended to choose screw $L \leq 20\text{mm}$ length fasteners.

5.2.3 Installation position and corresponding static loads

The low/normal level of load condition is applicable to the installation in most of environmental conditions: the maximum static load on the back of the modules is 2400 Pa (i.e. wind load), and the maximum static load on the front of modules is 2400 Pa (i.e. wind and snow load).

The high level of load condition is applicable to the installation in harsher environmental conditions such as storm, heavy snow, etc: the maximum static load on the back of the modules is 2400 Pa (i.e. wind load), and the maximum static load on the front of modules is 5400 Pa (i.e. wind and snow load), depending on the pressure level that it would endure according to IEC standard.

Special installation conditions If three horizontal bars are used throughout the installation, the horizontal bar in the middle area must be away from the junction box, and the edge of the horizontal bar must be more than 30mm away from the edge of the junction box.

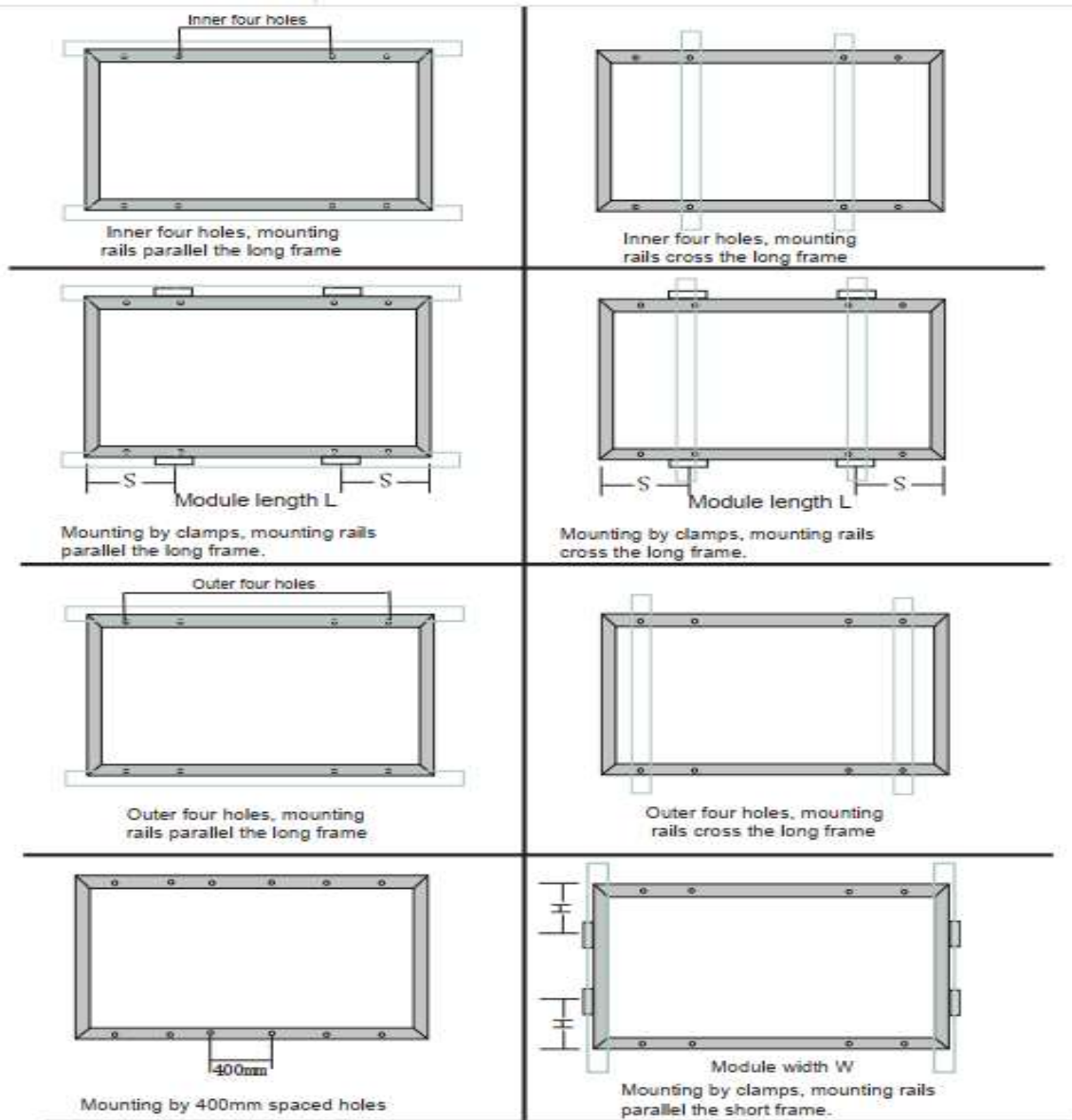

Installation methods Module type	Inner four holes, mounting rails parallel the long frame	Inner four holes, mounting rails cross the long frame	Clamps, mounting rails parallel the long frame S=1.4L±50	Clamps, mounting rails cross the long frame S=1.4L±50	mounting by 400mm spaced holes*	Outer four holes, mounting rails parallel the long frame	Outer four holes, mounting rails cross the long frame	Mounting by clamps on the short frame H=1.4W±50
JAM66D30 MB	±2400	+5400/-2400	±2400	+5400/-2400	±2400	N/A	N/A	N/A
JAM72D30 MB (35mm frame)	±2400	+5400/-2400	±2400	+5400/-2400	±2400	±2400	+5400/-2400	N/A
JAM78D30 MB (35mm frame)	±2400	+5400/-2400	±2400	+5400/-2400	±1800	±2400	+5400/-2400	N/A
JAM78D30 GB (35mm frame)	±2400	+5400/-2400	±2400	+5400/-2400	±1800	±2400	+5400/-2400	N/A
JAM78D40 GB (35mm frame)	±2400	+5400/-2400	±2400	+5400/-2400	±1800	±2400	+5400/-2400	N/A
JAM78D40 MB (35mm frame)	±2400	+5400/-2400	±2400	+5400/-2400	±1800	±2400	+5400/-2400	N/A
JAM72D42 LB (35mm frame)	±2400	+5400/-2400	±2400	+5400/-2400	±1800	±2400	+5400/-2400	N/A
JAM54D30 MB (1.6mm glass)	±2400	+5400/-2400	±2400	+5400/-2400	N/A	±2400	±2400	±1600
JAM54D30 GB (1.6mm glass)	±2400	+5400/-2400	±2400	+5400/-2400	N/A	±2400	±2400	±1600
JAM54D40 GB (1.6mm glass)	±2400	+5400/-2400	±2400	+5400/-2400	N/A	±2400	±2400	±1600
JAM54D40 MB (1.6mm glass)	±2400	+5400/-2400	±2400	+5400/-2400	N/A	±2400	±2400	±1600
JAM54D41 MB (1.6mm glass)	±2400	+5400/-2400	±2400	+5400/-2400	N/A	±2400	±2400	±1600
JAM54D40 LB (1.6mm glass)	±2400	+5400/-2400	±2400	+5400/-2400	N/A	±2400	±2400	±1600
JAM54D41 LB (1.6mm glass)	±2400	+5400/-2400	±2400	+5400/-2400	N/A	±2400	±2400	±1600

Installation methods Module type	Inner four holes, mounting rails parallel the long frame	Inner four holes, mounting rails cross the long frame	Clamps, mounting rails parallel the long frame 66: 450mm ≤ S ≤ 550mm; 72: 450mm ≤ S ≤ 550mm; 78: 500mm ≤ S ≤ 600mm; 72D42LB 550±50mm; 60D40LB 400mm ≤ S ≤ 500mm; 60D42LB 400mm ≤ S ≤ 500mm;	Clamps, mounting rails cross the long frame 66: 450mm ≤ S ≤ 550mm; 72: 450mm ≤ S ≤ 550mm; 78: 500mm ≤ S ≤ 600mm; 72D42LB 550±50mm; 60D40LB 400mm ≤ S ≤ 500mm; 60D42LB 400mm ≤ S ≤ 500mm;	mounting by 400mm spaced holes*	Outer four holes, mounting rails parallel the long frame	Outer four holes, mounting rails cross the long frame
JAM72D30 MB (30mm frame)	±2400	+5400/-2400	±2400	+5400/-2400	±1800	±2400	+5400/-2400
JAM78D30 MB (30mm frame)	±2400	+5400/-2400	±2400	+5400/-2400	±1800	±2400	+5400/-2400
JAM72D30 GB (30mm frame)	±2400	+5400/-2400	±2400	+5400/-2400	±1800	±2400	+5400/-2400
JAM78D30 GB (30mm frame)	±2400	+5400/-2400	±2400	+5400/-2400	±1800	±2400	+5400/-2400
JAM72D40 GB (30mm frame)	±2400	+5400/-2400	±2400	+5400/-2400	±1800	±2400	+5400/-2400
JAM72D40 MB (30mm frame)	±2400	+5400/-2400	±2400	+5400/-2400	±1800	±2400	+5400/-2400
JAM78D40 GB (30mm frame)	±2400	+5400/-2400	±2400	+5400/-2400	±1800	±2400	+5400/-2400
JAM78D40 MB (30mm frame)	±2400	+5400/-2400	±2400	+5400/-2400	±1800	±2400	+5400/-2400
JAM60D40 LB (30mm frame)	N/A	N/A	±2400	+5400/-2400	±2400	±2400	+5400/-2400
JAM60D42 LB (30mm frame)	±2400	+5400/-2400	±2400	+5400/-2400	±2400	±2400	+5400/-2400
JAM72D30 LB (30mm frame)	±2400	+5400/-2400	±2400	+5400/-2400	±2400	±2400	+5400/-2400
JAM72D40 LB (30mm frame)	±2400	+5400/-2400	±2400	+5400/-2400	±2400	±2400	+5400/-2400
JAM66D45 LB (30mm frame)	N/A	N/A	±2400	+5400/-2400	±1800	±2400	+5400/-2400
JAM66D42 MB (30mm frame)	±2400	+5400/-2400	±2400	+5400/-2400	±2400	±2400	+5400/-2400
JAM72D42 LB (30mm frame)	±2400	+5400/-2400	±2400	+5400/-2400	±1800	±2400	+5400/-2400
JAM66D46 LB (33mm frame)	N/A	N/A	±2400	+5400/-2400	N/A	±2400	+5400/-2400

Note: Test load= Design load*1.5 (security coefficient)

Note: 1. "N/A" means not applicable;

2. * This is 400mm mounting holes of 1P single axis tracking system (2.0mm thickness and above 60mm height purlin) , please consult with tracker companies about the workable installation solution if the required test load is over 2400Pa.

3. The mechanical loading data for the installation methods in the manual are based on the third-party certification or JA internal results.

4. Unless clearly marked in the table, the default glass thickness used in the module is 2.0mm.

5. For the maximum loads that do not appear in the table for certain installation methods, and for the other installation methods that doesn't appear in the table, please contact JA Solar for more details.

Figure 3 Installation Position and Corresponding Load Relation

5.2.4 Supporting bracket of photovoltaic installation and instructions

Supporting bracket of photovoltaic:

Photovoltaic module bracket usually choose corrosion resistance, weather resistance of steel or aluminum alloy materials, to ensure long-term durability and stability. According to the local climate conditions, the appropriate photovoltaic bracket materials and structures are selected to improve the ability of wind resistance, rain resistance and snow disaster resistance of the stent. At the same time, the wind direction, wind speed and other factors should be fully considered in the installation process, and reasonably arrange the installation Angle and position of the bracket.

During the installation of the photovoltaic module bracket, the operation should be carried out in strict accordance with the installation specifications and technical requirements of the photovoltaic bracket. Train installers to improve their technical level and operational standardization. At the same time, supervision and inspection should be strengthened during the installation process to ensure that each link meets the installation requirements.

The connection and node of the photovoltaic module bracket structure should meet the requirements of bearing capacity, reasonable structure, safe and reliable.

The design service life of the photovoltaic module support base should not be less than the design service life of the power station.

The main structural components of the photovoltaic module bracket should be connected by bolts. Bolt link and welding connection can be used between beams and columns.

The connection between photovoltaic module and photovoltaic module bracket should be in the form of fixed aluminum alloy press block standard parts, rail groove insertion or bolt fixing, and the module fixing bolt should be made of stainless steel.

Photovoltaic module supports require regular and comprehensive functional inspection and maintenance. This includes inspection of structural stability, correctness of component installation, and timely handling of potential safety hazards. For the faulty bracket, it should be repaired or replaced in time to ensure the normal operation of the photovoltaic system.

Tracking bracket:

The tracking support rod, purlin and spindle wall thickness shall meet the requirements of the design drawings.

Purlin and component frame C surface overlap at least 20mm.

The design service life of the tracking support base should not be less than the design service life of

the power station.

The length and height of different purlins of the tracking bracket correspond to different wind pressure and snow pressure. The matching test between the tracking support and photovoltaic modules should be completed before use. In case of special circumstances, please contact JA.

In the wind-resistant state, the tracking system should be able to withstand wind speeds of 33 m/s; In areas with winds above force 12, it should be able to withstand wind speeds of 42 m/s.

In snowy areas, the tracker system shall have a manual or automatic snow shelter function. In areas with high winds, the tracker system shall have a self-locking function.

In areas of low wind pressure and snow pressure, it is recommended that the size of the core component of the bracket to the assembly junction box cover is not less than 60mm, and the size of the core component of the bracket to the assembly junction box cover in high wind pressure and snow pressure areas is not less than 80mm.

For high wind load and snow load areas, if the tracking bracket installation method is used, it is recommended to use 2.5mm thickness and above 60mm height purlin installation with 790mm, 1200mm, 1400mm holes in the module frames, not 400mm installation hole to fasten the rails.

For low wind and snow load areas, if 400mm hole purlins are used for installation, the recommended thickness is not less than 2mm.

Regular comprehensive functional inspection and maintenance of tracking stents. This includes inspection of structural stability, correctness of component installation, and timely handling of potential safety hazards. For the faulty bracket, it should be repaired or replaced in time to ensure the normal operation of the photovoltaic system.

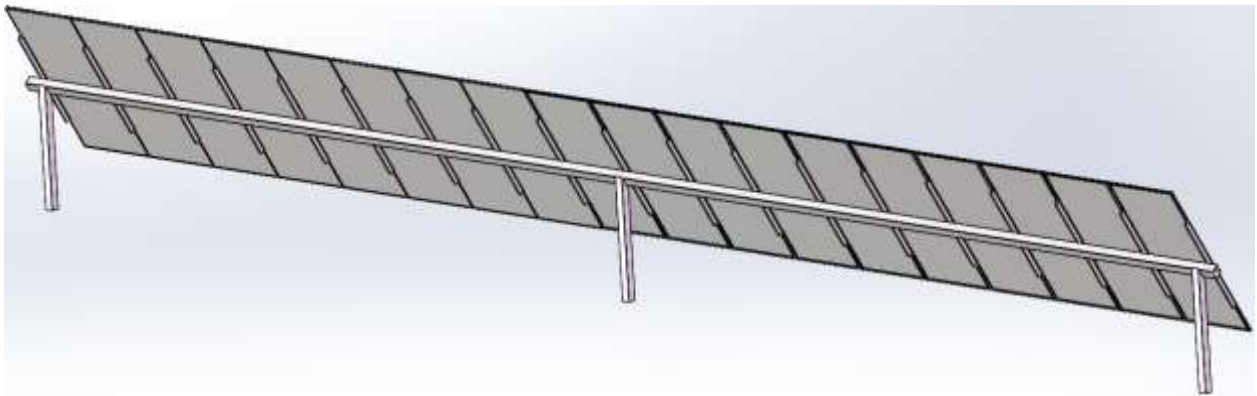

5.2.5 Installation instructions for the composite frame and the steel frame

A: Using the pressure block installation, the installation method and requirements of the composite frame assembly are consistent with the aluminum frame assembly.

B: Install with installation hole bolts. For the C face opening assembly of the composite frame, L-shaped gasket (material made: galvanized steel or aluminium alloy) is required for bolt installation, as illustrated in following figure.

C: Installation of screw support, with special screw support, as illustrated in following fig.

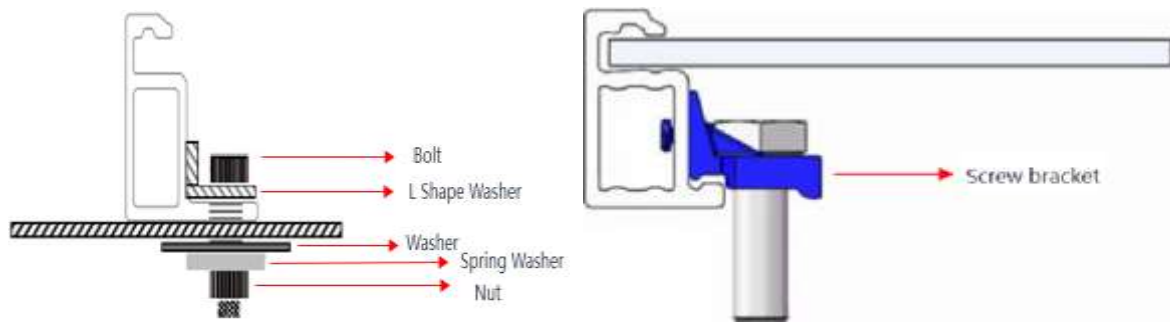

5.2.6 Steel frame

The material and installation method of the steel frame assembly are consistent with the aluminum frame assembly.

The steel frame assembly bolt is installed in the same way as the aluminum frame assembly.

Steel frame components is not recommended to be installed in such as heavy rain, seaside, chemical gas emission and so on.

6 Electrical Installation

6.1 Electrical Property

The rated electrical characteristics, I_{sc} is within $\pm 5\%$ and V_{oc} is within $\pm 3\%$ of measured values at Standard Test Conditions, but for the P_{max} , it is within $\pm 3\%$. Standard Test Conditions: $1000W/m^2$ Irradiance, $25^\circ C$ Cell Temperature and 1.5 Air Mass.

Under normal conditions, the photovoltaic modules may experience conditions that produce more current and/or voltage than reported at Standard Test Conditions. Accordingly, the values of short circuit current, I_{sc} , and open circuit voltage, V_{oc} , marked on modules should be multiplied by a factor of 1.25 when determining component voltage ratings, conductor capacities, fusing sizes, and size of controls connected to the module output.

Voltages are additive when modules are connected directly in series, and modules currents are additive when modules are connected directly in parallel, as illustrated in Figure 4.

Modules with different electrical characteristics must not be connected directly in series.

Series wiring

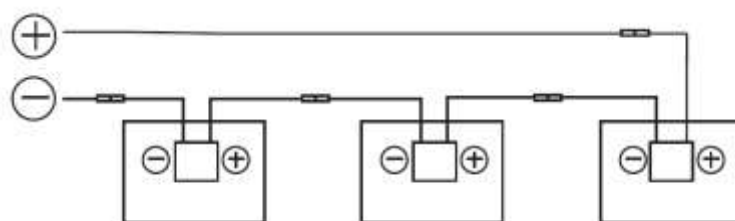

Parallel wiring

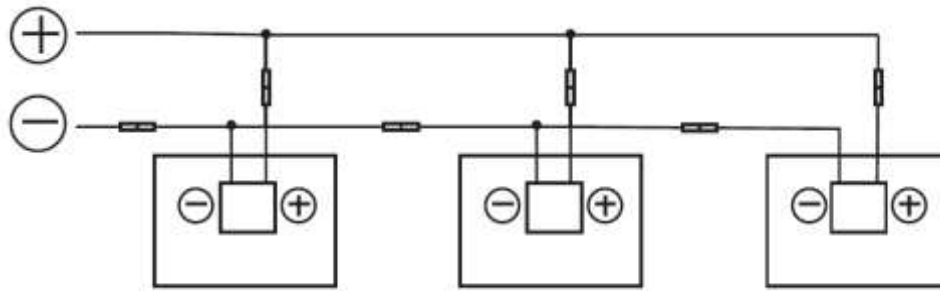

Series wiring and Parallel wiring

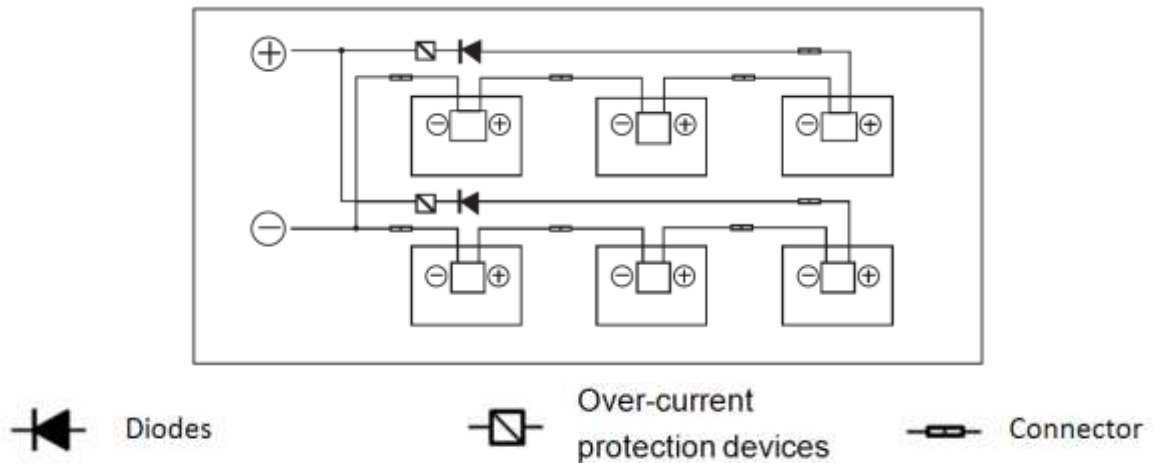

Figure 4: Electrical diagrams of series and parallel wiring

The maximum number of modules that can be connected in a series string must be calculated in accordance with applicable regulations in such a way that the specified maximum system voltage (The maximum system voltage of JA Solar modules is DC 1500V according to the safety appraisal of the IEC61730.) of the modules and all other electrical DC components will not be exceeded in open-circuit operation at the lowest temperature expected at the PV system location.

Correction factor for the open-circuit voltage can be calculated based on the following formula: $C_{Voc} = 1 - \beta_{Voc} \times (25 - T)$. T is the lowest expected ambient temperature at the system location. β (%/°C) is the temperature coefficient of the selected module Voc (refer to corresponding datasheet).

An appropriately rated over-current protection device must be used when the reverse current could exceed the value of the maximum fuse rating of the modules (30A or 35A). An over-current protection device is required for each series string if more than two series strings are connected in parallel, in Figure 4.

$$\text{Maximum system voltage} \geq N \times V_{oc} \times [1 + \beta \times (T_{min} - 25)]$$

Where:

N — number of modules connected in series

Voc — open circuit voltage of each module (refer to product nameplate or specification) [V]

β — thermal coefficient of open circuit voltage for the module (refer to the specification) [°C⁻¹]

Tmin — lowest ambient temperature [°C]

6.2 Cables and Wiring

These junction boxes have been designed to be easily interconnected in series for their well-connected

cable and the connector with IP68 protection grade. Each module has two single-conductor wires, one positive and one negative, which are pre-wired inside the junction box. The connectors at the opposite end of these wires allow easy series connection of adjacent modules by firmly inserting the positive connector of a module into the negative connector of an adjacent module until the connector is fully seated.

Use field wiring with suitable cross-sectional areas that are approved for use at the maximum short-circuit current of the modules. JA Solar recommends installers use only sunlight resistant cables qualified for direct current (DC) wiring in PV systems. The minimum wire size should be 4mm²(12AWG).

After connecting onsite cables, ensure that the cables are long enough and not tight. Otherwise, the connectors may be cracked or improperly inserted, which may cause system insulation alarms. It is necessary to use extension cables of the same model.

Rating Required Minimum Field Wiring

Testing Standard	Wire Size	Temperature Rating
EN 50618:2014	4mm ²	-40°C to +90°C

Cables should be fixed to the mounting rack or modules in such a way that mechanical damage of the cable and/or the modules is avoided. Do not apply stress to the cables. The minimum cables bending radius should be 38.4mm. Any cable damage caused by bending too much or cable management system is not covered under JA Solar's warranty. For fixing, use appropriate means, such as sunlight resistant cable ties and/or wire management clips specifically designed to attach to the module rack or modules. While the cables are sunlight resistant and waterproof, where possible, avoid direct sunlight exposure and water immersion of the cables.

Cable arrangement must comply with local laws and regulations.

6.3 Connectors

Keep connectors dry and clean, and ensure that connector caps are hand tight before connecting the modules. Do not attempt making an electrical connection with wet, soiled, or otherwise faulty connectors. Avoid sunlight exposure and water immersion of the connectors. Avoid connectors resting on the ground or roof surface.

Faulty connections can result in arcs and electrical shock. Check that all electrical connections are securely fastened. Make sure that all locking connectors are fully engaged and locked. Connector interconnect must reach the corresponding IP protection level, so as to achieve the electrical security. It is not recommended to interconnect different types of connectors.

Do not contact organic solvents and other corrosive materials in connector connection and the using environment, such as gasoline, pesticides, herbicides, etc. Please consult JA for details. Otherwise, JA will not be responsible for connector cracking caused by this aspect. Two examples of incorrect usage are listed below:



Please pay attention that the unlock method of connectors is different according to local laws and regulations.

During the construction of the power plant, the connector shall not be exposed to the outdoor environment under unconnected state for a long time, so as to avoid the invasion of dust, sand, insects,ect. in the environment to drill into the connector, resulting in the reliability decline of connector connection.

6.4 Bypass Diodes

The junction boxes used with JA Solar modules contain bypass diodes wired in parallel with the PV cell strings. In the case of partial shading, the diodes bypass the current generated by the non-shaded cells, thereby limiting modules heating and performance losses. Bypass diodes are not over-current protection devices.

In the event of a known or suspected diode failure, installers or maintenance providers should contact JA Solar. Never attempt to open the junction box by yourself.

Please pay attention to guard against inductive lightning, backflow and wrong connection.

7 Grounding

The grounding is only used on the framed bifacial modules. Frameless double glass modules and composite frame modules need not be grounded.

JA Solar modules use an anodic oxidized aluminium frame or steel frame to resist corrosion, so the frame of modules should be connected to the equipment grounding conductor to prevent thunder and static hurt.

The grounding device should fully contact with the inside of the aluminium frame and steel frame, and penetrate the surface of the frame oxidation film.

Please don't drill any additional grounding hole on the frame of the modules, otherwise JA Solar expressly disclaim liability for voiding the warranty.

To acquire the best power output, JA recommends clients to install modules with anti-PID inverter.

The grounding method should not result in the direct contact of dissimilar metals with the aluminium frame, Steel frame of the modules that will result in galvanic corrosion. IEC 60950-1 standard recommends

metal combinations not exceed an electrochemical potential difference of 0.6 Volts.

The frame rails have pre-drilled holes marked with a grounding sign. These holes should be used for grounding purposes and must not be used for mounting the modules.

The following grounding methods are available.

7.1 Grounding by Using Grounding Bolt

There is a grounding hole with 4.2 mm diameter on the edge side closer to the middle of the back frame of the modules. The middle line of the grounding mark is overlapped with the grounding hole, and the direction is same as the longer frame.

The grounding between modules must be approved by a qualified electrician. The grounding device must be produced by a qualified electrical manufacturer. The recommended torque value is 2.3 N.m. 12 AWG copper wire can be used as the equipment grounding conductor in conjunction with the grounding bolt. The copper wire should not be squashed during the installation.

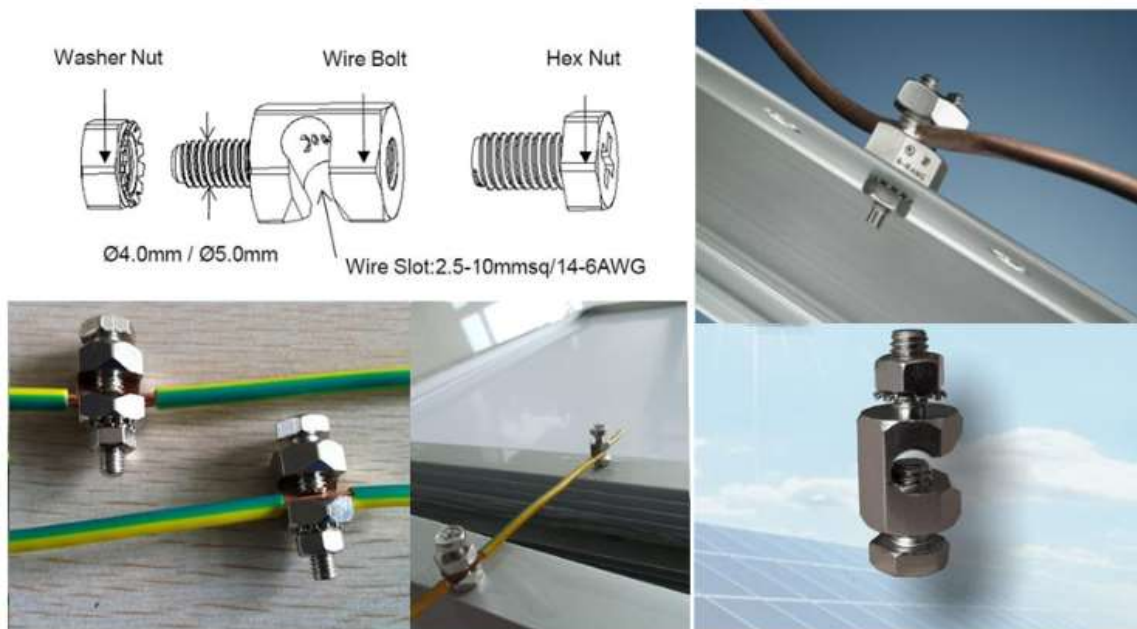

Figure 5: Installation methods

7.2 Grounding by using unused mounting hole

The existing mounting holes which have not been used can be used for grounding.

- A) Direct the grounding clamp to the mounting hole on the frame. Thread the grounding clamp and the frame with grounding bolt.
- B) Put the toothed gasket into the other side, then tighten and lock the nut. The recommended torque of locking the nut is 2.0 N.m~2.2 N.m.
- C) Thread the grounding clamp with grounding wire. The material and size of grounding wire should meet the relevant requirements of the national, regional and local code, law and standard.
- D) Finish the mounting with tightening the binding bolt of the grounding wire.

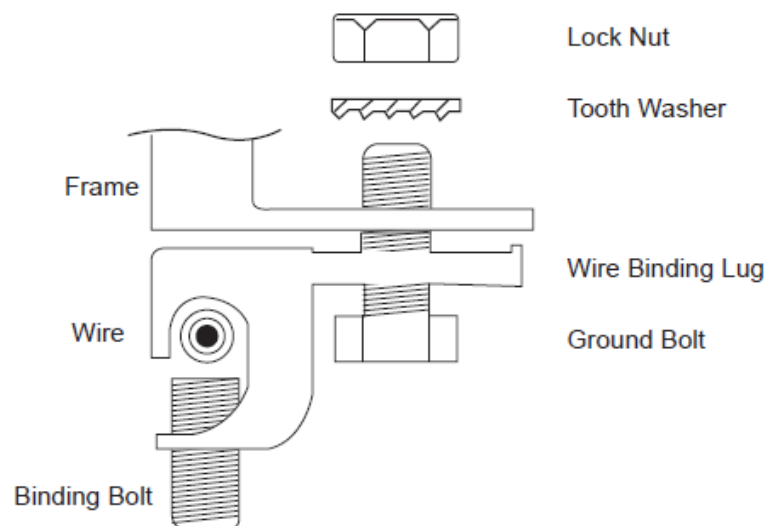

Figure 6: Installation methods

8 Operation and Maintenance

It is required to perform regular inspection and maintenance of the modules, especially within warranty scope. It is the user's responsibility to report to the supplier regarding the damages found within 2 weeks.

Pay attention to prevent foreign bodies such as lawn mowers and rolled up stones from hitting the surface of the modules, causing damage to the glass or modules.

8.1 Cleaning

The dust accumulated on the front transparent substrate may reduce the power output, and may even cause regional hot-spot effect. Industrial effluents or bird drops may be a serious case, and the extent of the severity depends on the transparency of the foreign objects. It's usually not dangerous for the accumulated dust to reduce the sunshine, because the light intensity is still homogeneous and the power reduction usually is not obvious.

When modules are operational, there may exist environmental factors that cast, dust, plants and so on, that may distinctly reduce the power output. JA Solar advises that there should be no obstructed object over the Module's surface at any time.

Standing on the module or bracket for cleaning works is forbidden.

The cleaning frequency depends on the accumulating velocity of the fouling. In many instances the front substrate is cleaned with the rain, and we can decrease the cleaning frequency. It is recommended to wipe the glass surface with wet sponge or soft cloth. Please do not clean the glass with cleaning agent which contains acid or alkali. Please refer to "cleaning manual" for specific contents.

8.2 The visual inspection of the modules

Inspect the modules visually to find if there are appearance defect, the following three types need more attention especially:

- A) Whether the glass is broken. When the glass of the module is broken: The module should be removed in time due to glass breakage or penetrating damage to the backsheet. Unauthorized use will cause the module to burn down and affect the operation of the power station.
- B) Corrosion along the cells' bus-bar.

The corrosion is caused by the dampness infiltrated into the modules when the surface encapsulation material is damaged during the installation or transportation.

- C) If there is burning vestige on the backsheet.

8.3 Inspection of the connector and the cable

It's recommended to implement the following preventive maintenance every 6 months:

- A) Check the encapsulation of the connector with the cable.
- B) Check the sealing gel of the junction box to ensure it is not cracked or creviced.

Product Supplement

The installation manual applicable module types are as follows. The module types are subject to changes without prior notice due to continuous product innovation, research and development.

“XXX” shows the PEAK power of the Module Label in increments of 5.

Module types	Power range[W]	Dimension(LxWxH)[mm]
JAM66D45-XXX/LB	580-620	2382x1134x30
JAM66D42-XXX/MB	540-595	2278x1134x30
JAM72D42-XXX/LB	605-650	2465x1134x35/30
JAM72D40-XXX/LB	560-615	2333x1134x30
JAM54D40-XXX/LB	420-460	1762x1134x30
JAM54D41-XXX/LB	420-455	1762x1134x30
JAM72D30-XXX/MB	530-555	2278x1134x30
JAM72D40-XXX/MB	560-605	2278x1134x30
JAM72D40-XXX/GB	560-605	2278x1134x30
JAM60D40-XXX/LB	485-510	1953x1134x30
JAM60D42-XXX/LB	500-540	2063x1134x30

Note: 1. The mounting installation of black modules refer to the white modules of the same dimension.